

Cellboost™

Value Pack for iPod® &
Value Pack for iPod mini®

Instruction Manual

iRecharge

Value Pack for iPod

Value Pack for iPod mini

Congratulations! Thank you for buying the Value Pack for iPod by Cellboost. Before using your Value Pack please read this instruction manual to learn about its features and capabilities and how to get the best from it.

iPod is a registered trademark of Apple Computer, Inc.
Cellboost is a registered trademark of Compact Power Systems, Inc.
iRecharge is a trademark of Compact Power Systems, Inc.

Contents

What comes in your Value Pack?	4
Cellboost for iPod	
Operating Instructions	5
iRecharge for iPod	
Product Overview	6
Getting Started	7
Product Setup	9
Using your iRecharge	11
Charge indicators (LEDs)	14
Charging instructions	15
Genuine Leather Protective Case	18
iRecharge Rapid Replacement 3-Year Warranty	20

What comes in your Value Pack?



**Cellboost for
iPod (Disposable
battery/charger)**

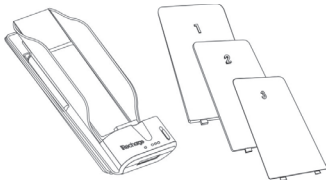

**iRecharge
(Rechargeable
battery pack)**

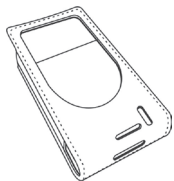

**Genuine Leather
Protective Case**

NOTE: Value Pack
for iPod mini does not
include spacer plates

Cellboost for iPod

Operating instructions

1. Remove the protective cap and plug your Cellboost into your iPod's charging port.

NOTE: To maximize play time, use while your iPod is "on"

2. Use Cellboost as many times as you like until it is empty.

3. Once your Cellboost is empty, please dispose of properly.



iRecharge for iPod

Product Overview

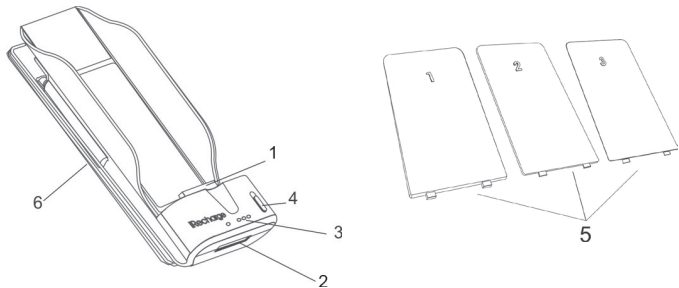

1. iPod dock connector (to connect your iPod to the iRecharge)
2. Dock connector port (to charge your iRecharge using your iPod charger)
3. Charge indicators (LEDs)
4. On/Off switch
5. Spacer plates for compatibility with all Standard iPod models (not mini)
6. Removable belt clip

NOTE: Value Pack for iPod mini does not include spacer plates

iRecharge for iPod

Getting Started

Charging iRecharge for the first time

Before using your iRecharge for the first time, you will need to charge its battery.

You can charge it using any Apple dock connector charging cable that came with your iPod.

1. Connect your iPod cable to the port located on the bottom of your iRecharge. Connect the other end, to either the AC adapter or your PC's USB port.

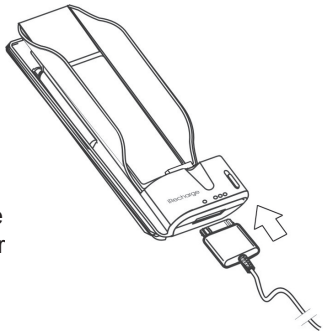

Getting Started (continued)

2. Leave your iRecharge connected until it is completely charged (usually 4-8 hours). Your iRecharge is fully charged when all four LEDs are visible on the front panel.

3. When your iRecharge is fully charged, disconnect it and follow the product setup instructions.

NOTE: Charging time depends on the charging method you are using. Charging from the FireWire or USB port of your PC is slower than using an AC outlet.

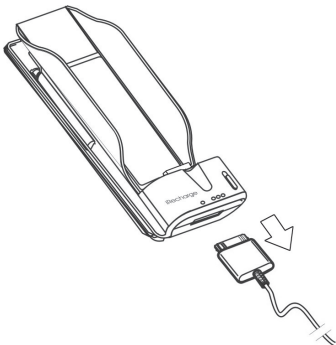

iRecharge for iPod

Product Setup

Cellboost makes two different iRecharge models: iRecharge for iPod and iRecharge for iPod mini. If your iRecharge is for iPod mini models, please skip this section.

Different iPod models have different thicknesses; the spacer panels will help you configure your iRecharge for a perfect fit. Select one of the spacer plates according to your iPod model.



Spacer Plate #1:
iPod 20GB



Spacer Plate #2:
iPod 40GB
iPod video 60GB



Spacer Plate #3:
iPod Photo 30GB
iPod video 30GB

No spacer plate required for

iPod photo 40GB
iPod photo 60GB
iPod mini models

NOTE: Works only with iPod models with dock connector and click wheel.

Product Setup (continued)

If your model needs a spacer plate, slide it into iRecharge until it clips firmly into place.

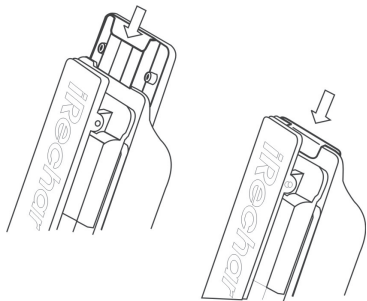

iRecharge for iPod

Using your iRecharge

1. Now that your iRecharge is fully charged, connect your iPod to the iRecharge. To do this, just slide your iPod into the iRecharge from the top.

Note: Make sure the iPod dock connector port is lined up with the iRecharge dock connector.

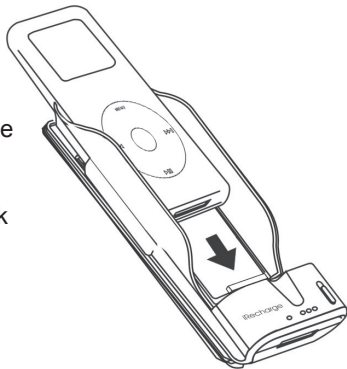

Using your iRecharge (continued)

2. To charge your iPod's battery using iRecharge, slide the switch located in the front panel of iRecharge to the ON (up) position. You will be able to see that your iRecharge is ON in two ways:

1. One or more charge indicator LEDs in the front panel of iRecharge are on.
2. A charging icon in the top right corner or a large charge icon appears on your iPod's LCD screen.

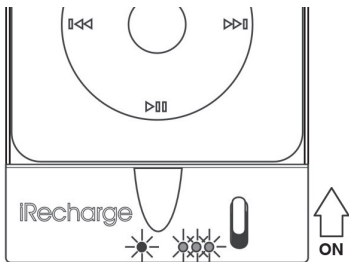

Using your iRecharge (continued)

3. When the battery of your iPod is charged, switch your iRecharge to the OFF (down) position. Charging icons and the charge indicator LEDs will turn off. When not in use, turn your iRecharge to the OFF position to conserve power.

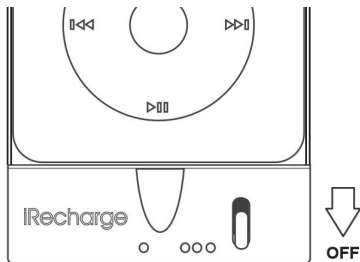

iRecharge for iPod

Charge indicators (LEDs)

The front panel of your iRecharge includes 4 LEDs to indicate the charge status of the iRecharge battery. Indication is as follows:

- 1 red light, 3 green lights on: fully charged (90%-100%)
- 1 red light, 2 green lights on: 60-70% charge
- 1 red light, 1 green lights on: 10-15% charge
- 1 red light on: less than 10% charge

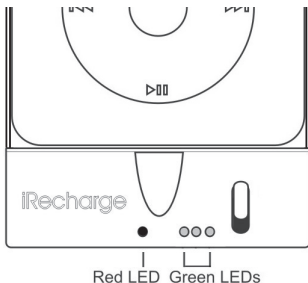

iRecharge for iPod

Charging instructions

You can charge iRecharge alone following the “Charging for the first time” instructions or you can charge your iRecharge and your iPod together:

1. Connect your iPod to the iRecharge. Slide your iPod in from top to bottom. Make sure your iRecharge is in the “ON” position (up).

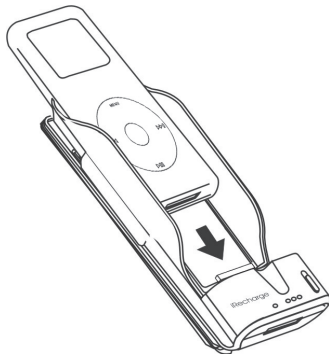

Charging instructions (continued)

2. Connect your iPod dock connector cable to the port located on the bottom of your iRecharge and connect the other end to either the AC adapter or your PC. You may use any Apple original charger cable:

- FireWire® cable with AC Adapter
- USB cable with AC Adapter
- FireWire® Cable to PC
- USB cable to PC*

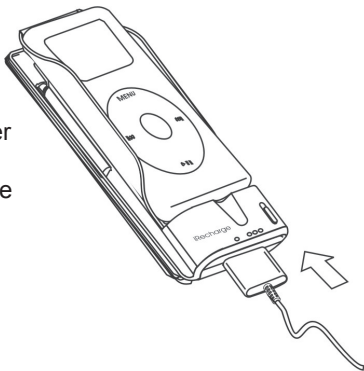

NOTE: Charging time depends on the charging method you are using. Charging from the FireWire® or USB port of your PC is generally slower than using an AC outlet.

* If your iRecharge and your iPod are completely discharged, switch your iRecharge to the "OFF" (down) position during the first 30 minutes of the charging cycle. After 30 minutes, switch it to the "ON" (up) position to allow your iPod to charge.

Charging instructions (continued)

3. iRecharge is fully charged when all four LEDs are visible on the iRecharge front panel.

4. The iRecharge internal battery and your iPod will charge simultaneously. Charge until all four LEDs are visible on the front panel of iRecharge and a charged battery icon appears on your iPod.

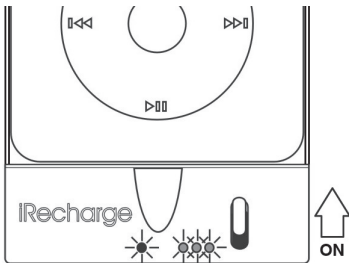

5. When both devices register fully charged, disconnect the charger.

NOTE: Data cannot be transferred to your iPod if it is connected to the iRecharge.

IMPORTANT: Like all products containing lithium-ion batteries, iRecharge will slowly discharge when not in use. If you plan to store iRecharge for long periods, store it in a cool, dry place and charge it for 10-15 minutes every 6 months.

Genuine Leather Protective Case

The genuine leather protective case exclusive design protects your iPod and iRecharge while you use them. The iRecharge genuine leather protective case features a clear window to protect your iPod LCD screen and convenient openings to allow full connectivity.

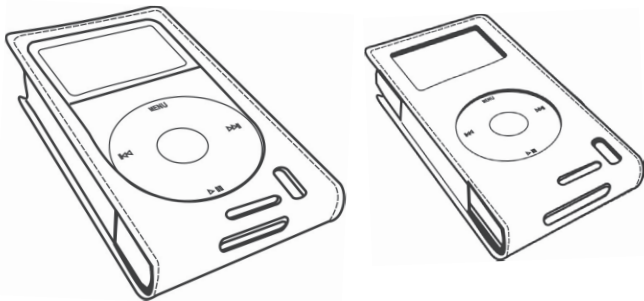

iRecharge Rapid Replacement 3-Year Warranty Service

iRecharge Rapid Replacement 3-Year Warranty Service
Compaq Power Systems' warranty obligations for iRecharge are limited to the terms set forth below:

Compaq Power Systems, Inc. ("CPS") warrants the iRecharge product against defects in materials and workmanship for a period of three (3) years from the date of original purchase ("Warranty Period").

If a defect arises and a valid claim is received by CPS within the Warranty Period, at its option, CPS will (1) repair the product at no charge, using new or refurbished replacement parts, (2) exchange the product with a product that is new or which has been manufactured from new or serviceable used parts and is at least functionally equivalent to the original product, or (3) refund the purchase price of the product.

If a defect arises and a valid claim is received by CPS after the Warranty Period, a shipping and handling charge will apply to any repair or exchange of the product undertaken by CPS.

When a product or part is exchanged, any replacement item becomes your property and the replaced item becomes CPS's property. When a refund is given, your product becomes CPS's property.

EXCLUSIONS AND LIMITATIONS

CPS is not liable for any damage or your portable device or loss of any programs, data, or other information stored on any media contained within your device or any non-CPS product or part not covered by this warranty. Recovery or reinstallation of programs, data or other information is not covered under this Limited Warranty.

This warranty does not apply: (a) to damage caused by accident, abuse, misuse, misapplication, or non-CPS products; (b) to damage caused by service performed by anyone other than CPS; (c) to a product or a part that has been modified without the written permission of CPS; or (d) if any CPS serial number has been removed or defaced.

TO THE MAXIMUM EXTENT PERMITTED BY LAW, THIS WARRANTY AND THE REMEDIES SET FORTH ABOVE ARE EXCLUSIVE AND IN LIEU OF ALL OTHER WARRANTIES, REMEDIES AND CONDITIONS, WHETHER ORAL OR WRITTEN, EXPRESS OR IMPLIED. CPS SPECIFICALLY DISCLAIMS ANY AND ALL IMPLIED WARRANTIES, INCLUDING, WITHOUT LIMITATION, WARRANTIES OF MERCHANTABILITY AND FITNESS FOR A PARTICULAR PURPOSE. IF CPS CANNOT LAWFULLY DISCLAIM OR EXCLUDE IMPLIED WARRANTIES UNDER APPLICABLE LAW, THEN TO THE EXTENT POSSIBLE ANY CLAIMS UNDER SUCH IMPLIED WARRANTIES SHALL EXPIRE ON EXPIRATION OF THE WARRANTY PERIOD. No CPS reseller, agent, or employee is authorized to make any modification, extension, or addition to this warranty.

TO THE MAXIMUM EXTENT PERMITTED BY LAW, CPS IS NOT RESPONSIBLE FOR DIRECT, SPECIAL, INCIDENTAL OR CONSEQUENTIAL DAMAGES RESULTING FROM ANY BREACH OF WARRANTY OR CONDITION, OR UNDER ANY OTHER LEGAL THEORY, INCLUDING BUT NOT LIMITED TO, LOST PROFITS, DOWNTIME, GOODWILL, DAMAGE TO OR REPROGRAMMING OR REPRODUCING, ANY PROGRAM OR DATA STORED IN OR USED WITH CPS PRODUCTS.

How to get Rapid Replacement warranty service:

1. For information on obtaining Rapid Replacement warranty service, email Compact Power Systems customer service at customerservice@cpsyst.com or call Compact Power Systems. Compact Power Systems' Rapid Replacement Customer Support telephone numbers are (toll free): in the **U.S (800) 833-1070**.
2. To obtain Rapid Replacement warranty service, you will be required to provide:
 - A. The original dated sales slip
 - B. Your name
 - C. Your address and e-mail
 - D. The serial number of the product
 - E. The product name, where purchased and a description of the problem.
3. Take or ship the product in the original or a properly padded, protective replacement container to CPS at the below address:

Compact Power Systems Rapid Replacement Warranty Service
7801 Hayvenhurst Ave.
Van Nuys, CA 91406

Cellboost™

Compact Power Systems, Inc.

www.Cellboost.com
(800) 833-1070